

## In-Sight Cant Indicator Eyepiece Cap

Lens cap with built-in level

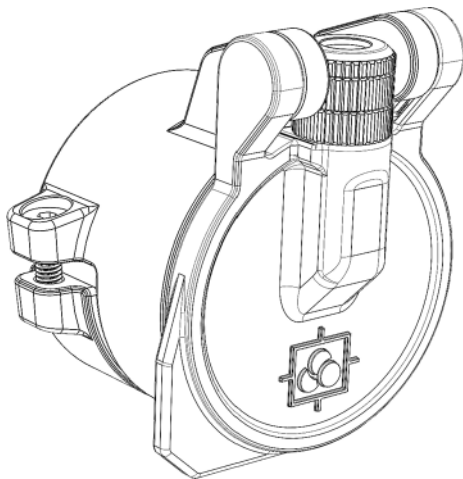

### Contents

1. Specifications
2. Package Contents
3. Installation and Alignment
4. Maintenance and Warranty

## 1. Specifications

Parameter	Value
Dimensions (closed), mm	57 x 66 x 47
Weight, g	35 g
Supported eyepiece diameters, mm	40-46
Supported eyepiece exit pupil distances	80-110

## 2. Package Contents

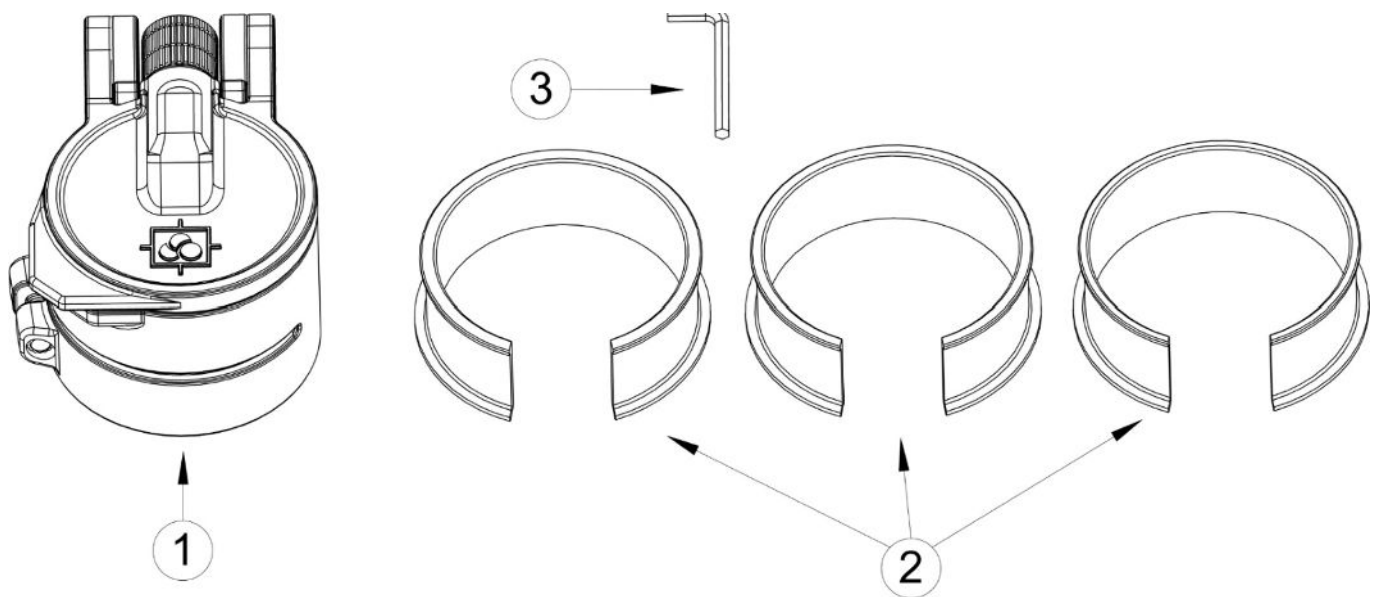

Pic. 1

1. In-Sight Cant Indicator Eyepiece Cap
2. Set of spacers for installing the cap on eyepieces of different diameters.
3. Allen key for installing and adjusting the cap.

### 3. Installation and Alignment

Prior to attaching the cap to the scope, please adjust the dioptical setting to suit your vision by rotating dioptical ring (see Pic. 2) clockwise or counterclockwise until the bubble level module appears as sharp as possible.

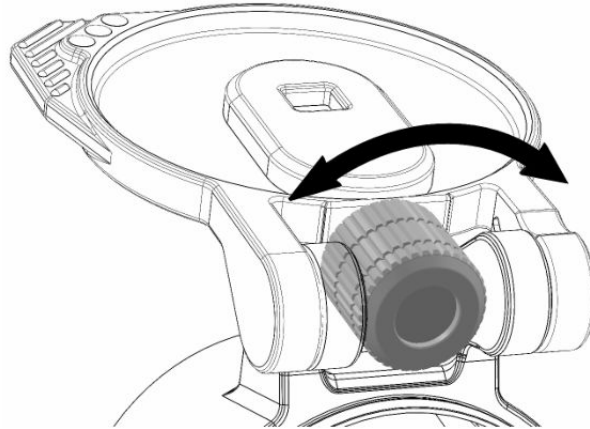

Pic. 2

Select the most appropriate insert (see Pos. 2, Pic. 1) that provides an optimal fit to your scope eyepiece. Insert the selected insert into the cap with the marker facing outward (see Pos. A, Pic. 3) until the outer flange of the insert touches the end of the cap (see Pic. 4). To make insertion easier, squeeze the insert slightly on the sides with your fingers. Then place the eyepiece cap with insert onto the eyepiece.

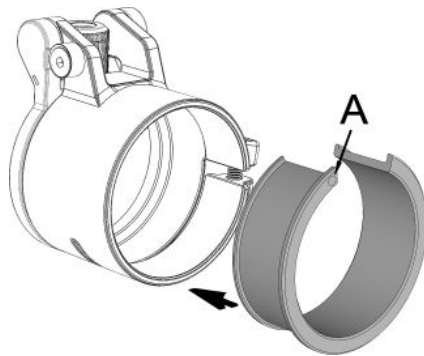

Pic. 3

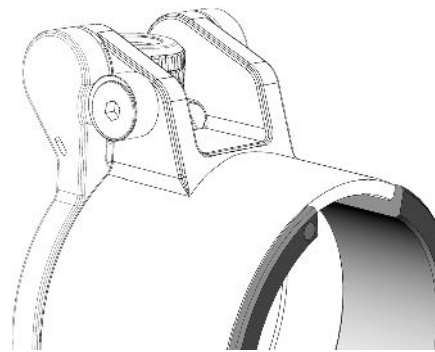

Pic. 4

With the gun and the scope positioned so they are levelled, rotate the cap until the bubble is balanced (see Pic. 5), then securely fasten screw (see Pic. 6).

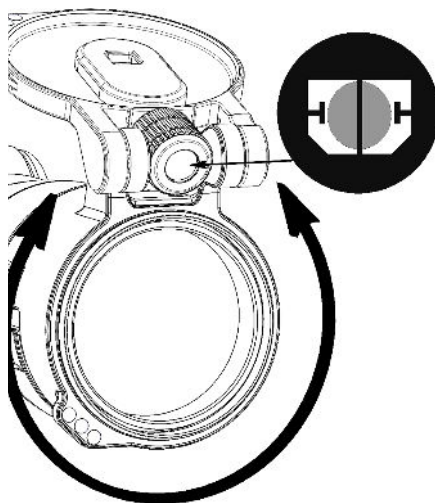

Pic. 5

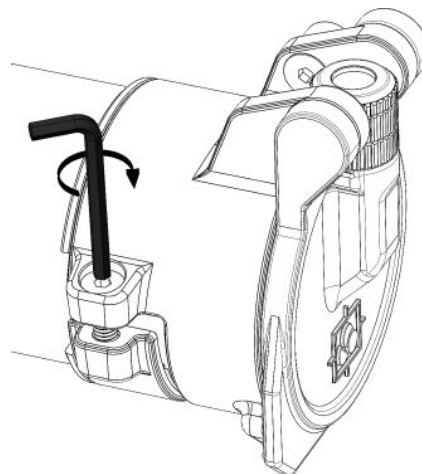

Pic. 6

Look through the scope's eyepiece as you normally would when shooting. Then, without moving your head, but only looking at the bubble window, adjust the tilt of the cover using the side screw until you see the bubble as clearly as possible (see Pic. 7).

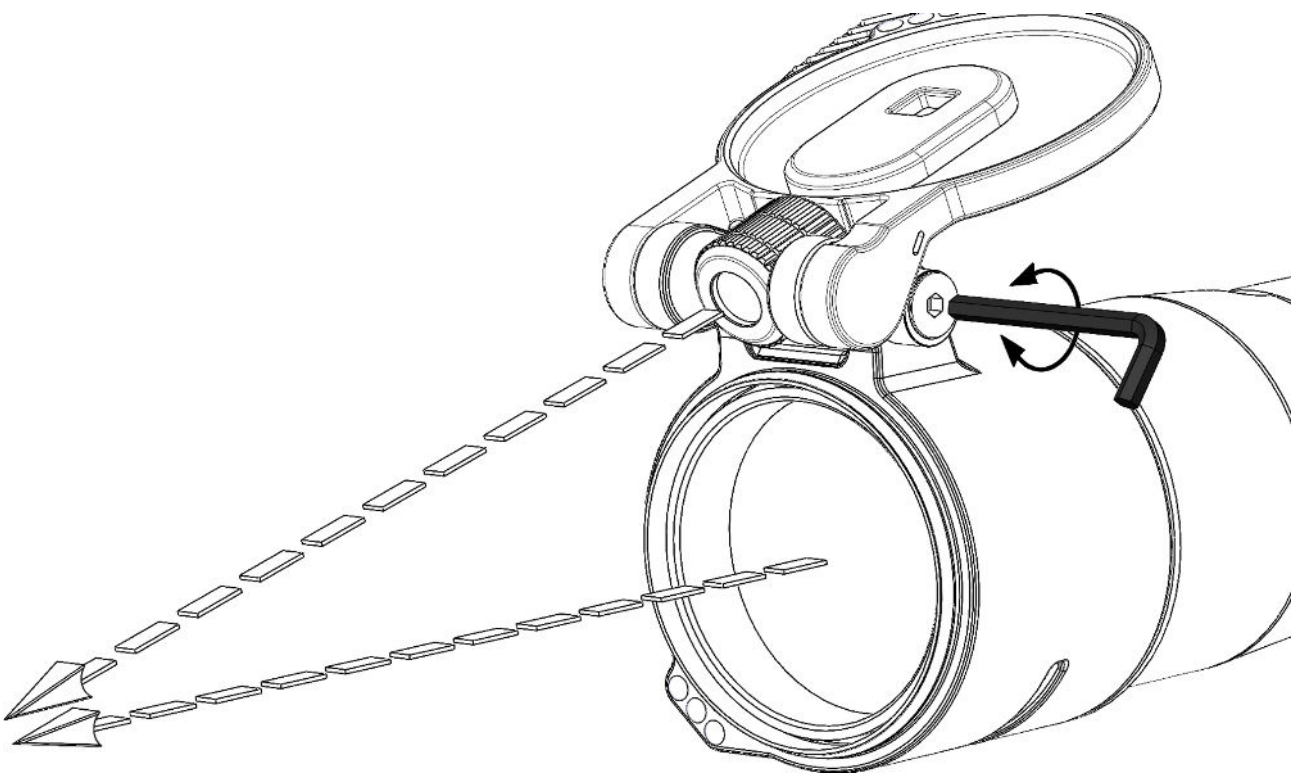

Pic. 7

## 4. MAINTENANCE AND WARRANTY

### Maintenance advice

- Clean optical surfaces only with optical soft cloth. Do not apply force when cleaning.

### Warranty

- The Manufacturer provides warranty for its products against material and workmanship defects for a period of 3 years, starting from the day of purchase.
- The warranty does not cover damage caused by misuse, improper installation, unauthorised modification, impact damage, or normal cosmetic wear.
- To support a warranty claim, retain proof of purchase and provide product details together with a clear description of the fault.

**Support:** For product support or warranty enquiries, contact Immersive Optics with the product description, purchase details and photographs of the issue where possible.

---

**Immersive Optics Limited**  
**Unit D, Cloberfield Business Centre**  
**15 Cloberfield, Glasgow**  
**G62 7LN, United Kingdom**

**[www.immersive-optics.com](http://www.immersive-optics.com)**